















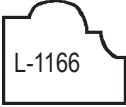











# TRIMS FIR & HEM

	SCREEN MOLD 3/4 HEM		BASE CAP 5/8 X 3/4 HEM		BN STOP 1/2 X 7/8 HEM
	ALICIA MOLD 5/8 FIR		L-1235 BASE CAP 1/2 X 1 HEM		BN STOP 1/2 X 1-1/16 HEM
	L-1166 GLASS BEAD 1/2 FIR		L-1108 BASE CAP 5/8 X 1-1/16 FIR		BN STOP 1/2 X 1-3/8 HEM
	BEAD COVE 3/8 X 3/8 FIR		OG BASE SHOE 1/2 X 1-3/8 FIR		BN STOP 1/2 X 1-5/8 HEM
#155 Glass Bead profile" data-bbox="88 386 144 421"/>	#155 GLASS BEAD 3/8 X 7/16 FIR		L-1137 BASE CAP 11/16 X 1-3/8 FIR		BN STOP 1/2 X 2-1/4 HEM
#046 Glass Bead profile" data-bbox="88 461 174 511"/>	#046 GLASS BEAD 5/8 HEM		L-1157 BASE CAP 11/16 X 1-3/8 FIR		LATTICE 1/4 X 1-1/6 HEM
	BEVEL STOP 7/16 X 9/16 FIR		L-1157 BASE CAP 11/16 X 1-3/8 FIR		LATTICE 1/4 X 1-5/16 HEM
	L-1177 WINDOW STOP 3/4 FIR		L-1202 OG BASE CAP 5/8 X 1-5/8 FIR		LATTICE 1/4 X 1-5/8 HEM
	L-1197 WINDOW STOP 1/2 X 5/8 FIR		L-1182 OG STOP 5/8 X 7/8 FIR		LATTICE 1/4 X 2-1/8 HEM
	OG STOP 7/16 X 1-3/8 HEM		L-1176 BEVEL BASE CAP 5/8 X 1-5/8 FIR		L-1175 FILLET 7/16 x 1-1/4 FIR AND F/J PRIMED

# TRIMS FIR & HEM

## PANEL CAPS HEM

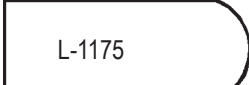
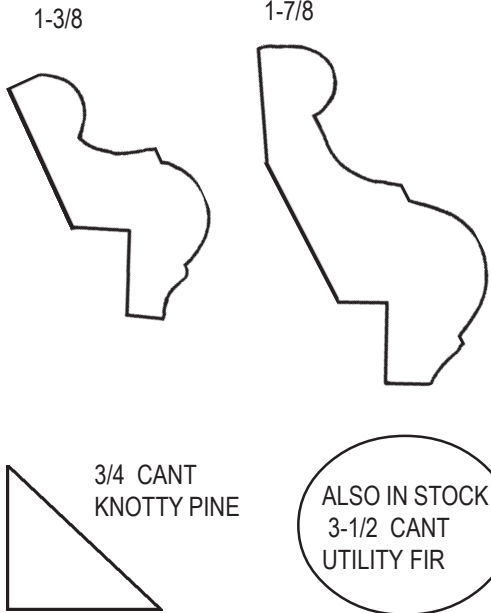

## WAINSCOT CAPS HEM

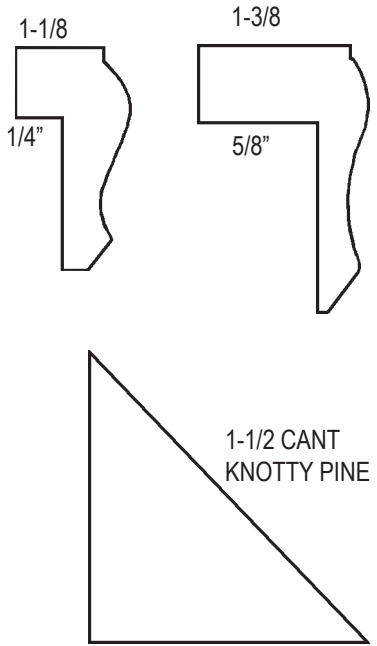

## OUTSIDE CORNERS HEM

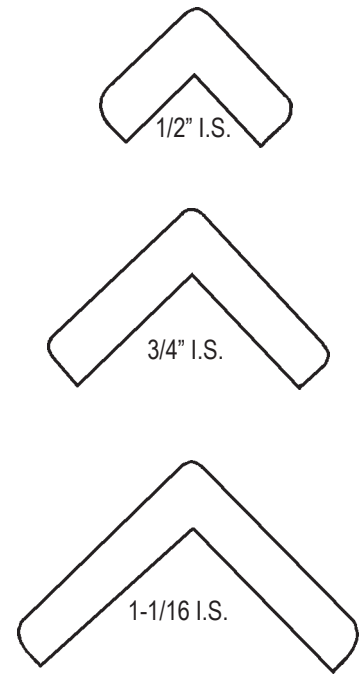

## QUARTER ROUNDS HEM

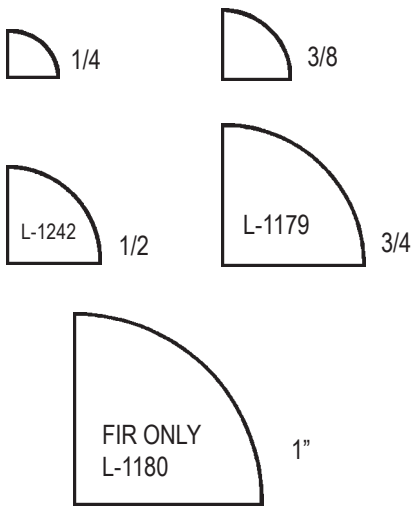

## HALF ROUNDS HEM

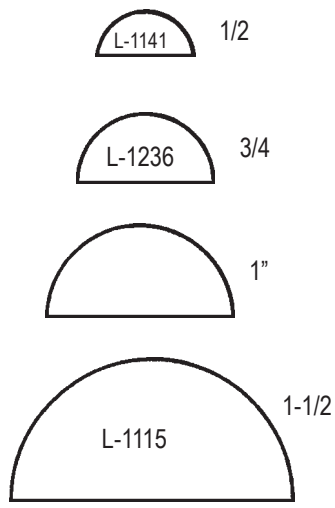

## ROUNDS HEM

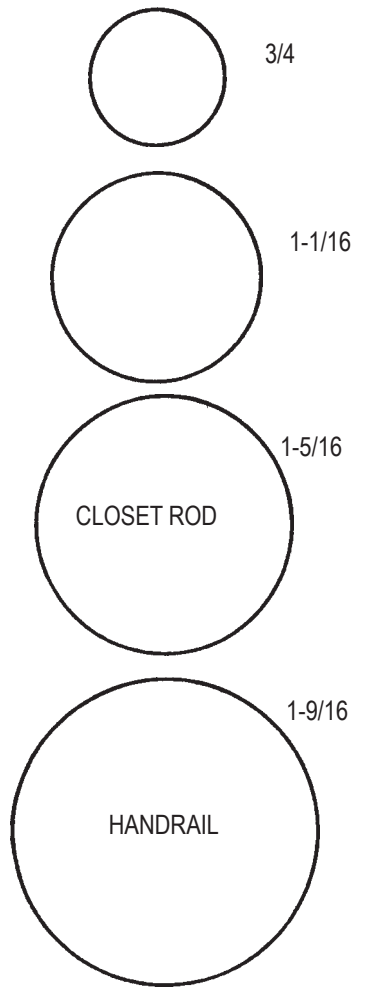

## SQUARES HEM

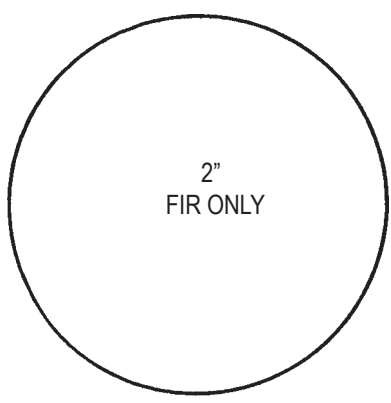
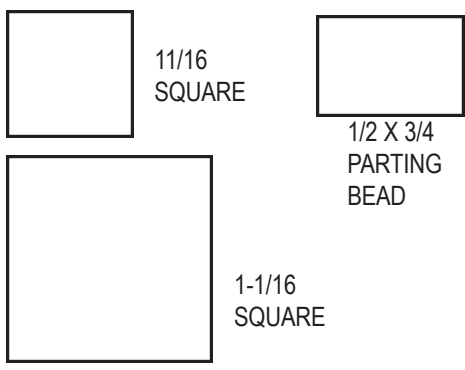

# CASINGS      FIR & HEM



WEDGE  
1/2 X 1-1/2  
HEM

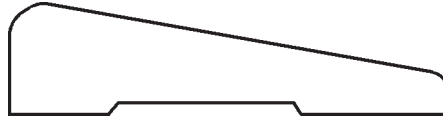

WEDGE  
1/2 X 2-1/4  
HEM



BULL NOSED  
1/2 X 1-1/2  
HEM



BULL NOSED  
1/2 X 2-1/4  
HEM

BULL NOSED  
11/16 X 2-1/2  
V.G. HEM AND V.G. FIR

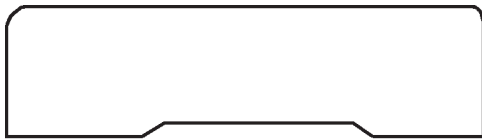

BULL NOSED  
11/16 X 3-1/2  
V.G. HEM AND V.G. FIR



STREAMLINE  
1/2 X 1-5/8  
HEM

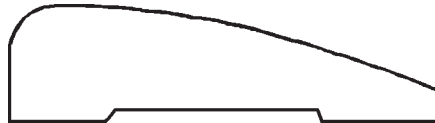

STREAMLINE  
1/2 X 2-1/4  
HEM

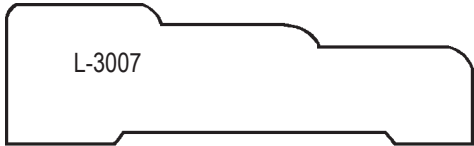

MOLDED  
5/8 X 2-3/8  
V.G. FIR

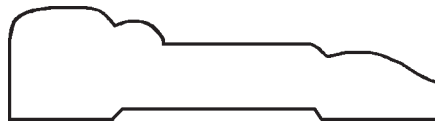

MOLDED  
9/16 X 2-1/4  
HEM

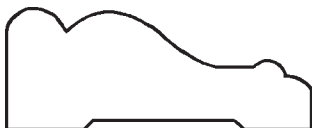

BEADED  
1/2 X 1-1/2  
HEM

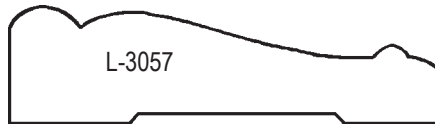

BEADED  
1/2 X 2-1/4  
HEM

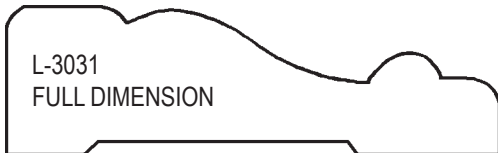

BEADED  
3/4 X 2-1/2  
V.G. FIR



BEADED  
9/16 X 2-1/2  
HEM

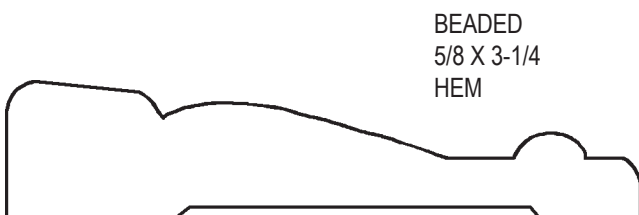

BEADED  
5/8 X 3-1/4  
HEM



CALYPSO  
5/8 X 2-3/8  
V.G. FIR

# CASINGS    FIR & HEM

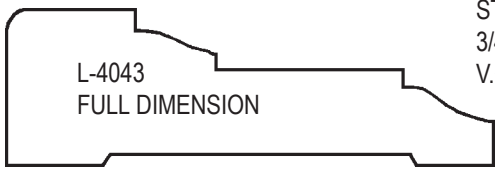

L-4043  
FULL DIMENSION

STEP  
3/4 X 2-1/2  
V.G. FIR

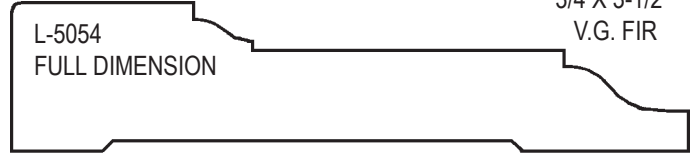

L-5054  
FULL DIMENSION

STEP  
3/4 X 3-1/2  
V.G. FIR

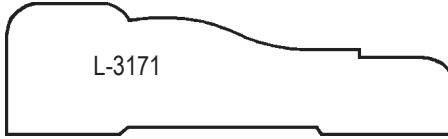

L-3171

COLONIAL  
11/16 X 2-1/4  
HEM

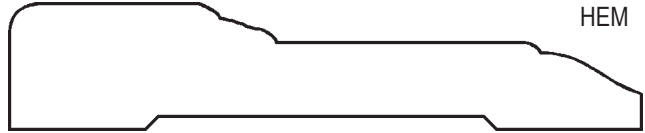

STEP  
9/16 X 3-3/8  
HEM

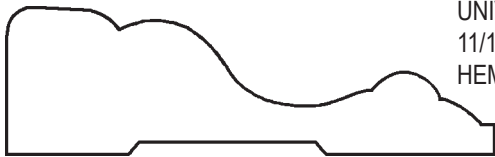

UNIVERSAL  
11/16 X 2-1/2  
HEM

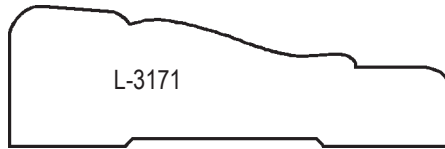

L-3171

COLONIAL  
11/16 X 2-1/4  
V.G. FIR

# BASES FIR & HEM

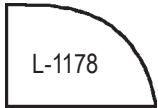

BASE SHOE  
1/2 X 3/4  
HEM, FIR & PRE-PRIMED  
IN STOCK

L-1178

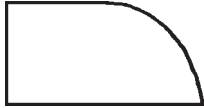

BASE SHOE  
1/2 X 1"  
FIR



STREAMLINE BASE  
7/16 X 1-1/2  
HEM

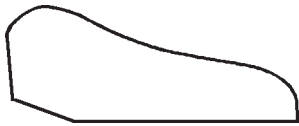

SANITARY BASE  
STYLE "B"  
9/16 X 1-1/2  
HEM



COLONIAL BASE  
3/8 X 3-1/4  
HEM



O.G. BASE  
7/16 X 2-1/4  
HEM



L-2091

O.G. BASE  
5/8 X 2-3/8  
V.G. FIR



STREAMLINE BASE  
7/16 X 2-1/4  
HEM



STREAMLINE BASE  
7/16 X 3-1/4  
HEM



L-4036

STREAMLINE BASE  
5/8 X 3-1/4  
V.G. FIR



SANITARY BASE  
STYLE "A"  
7/8 X 2-1/4  
HEM



SANITARY BASE  
STYLE "B"  
11/16 X 2-1/4  
HEM



O.G. BASE  
7/16 X 3-1/4  
HEM



L-2091

O.G. BASE  
5/8 X 3-1/4  
V.G. FIR

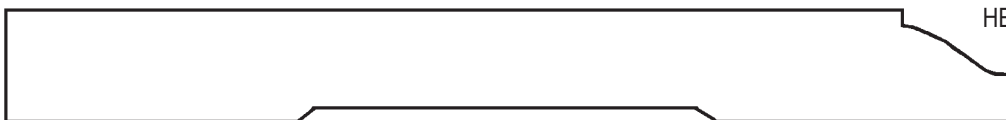

O.G. BASE  
9/16 X 5-1/4  
HEM

# COVES      FIR & HEM

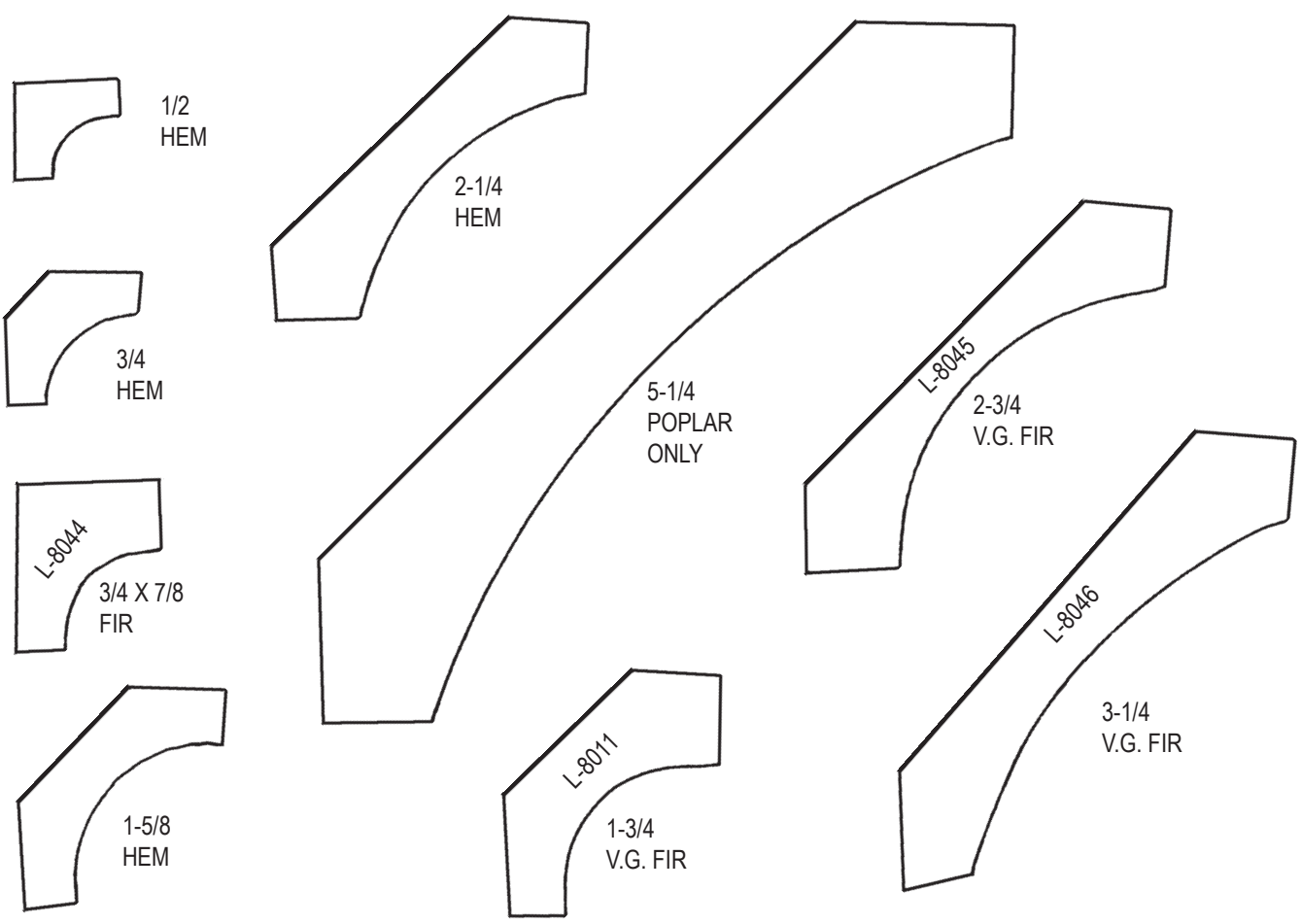

# BED MOULDING      FIR

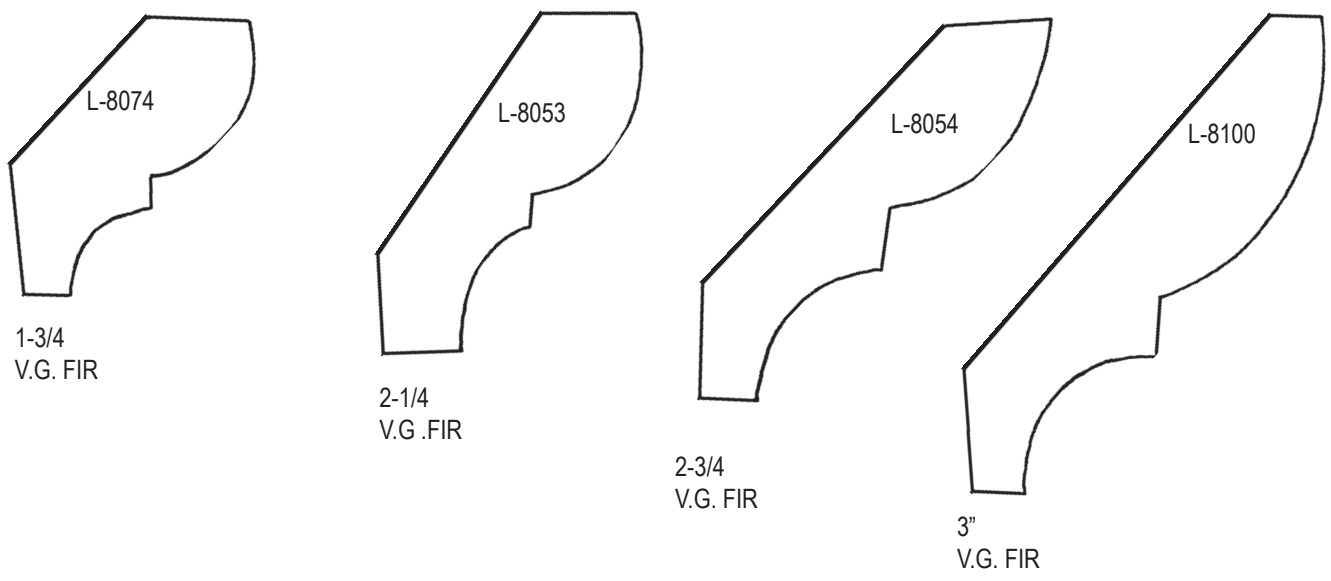

# CROWNS    FIR & HEM

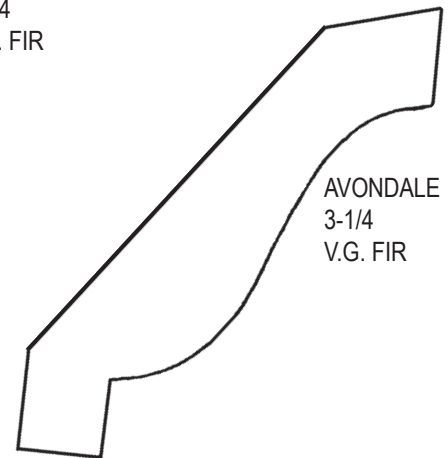
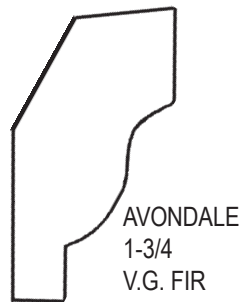
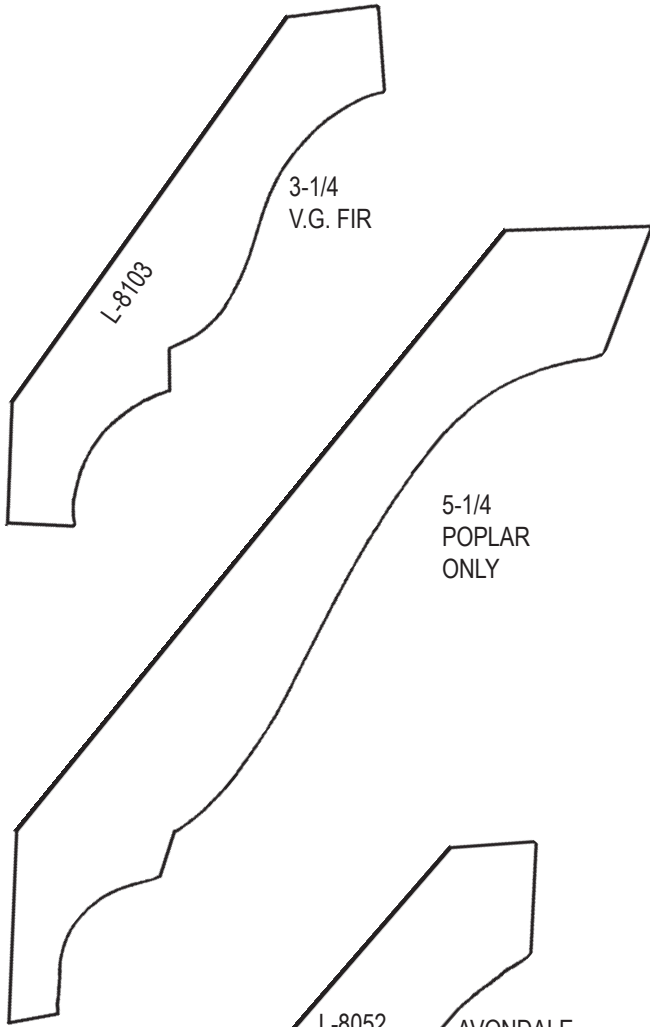
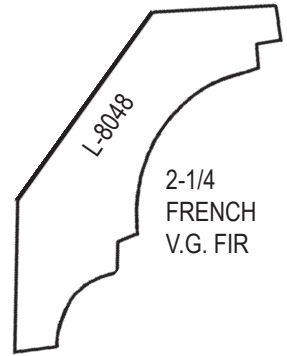
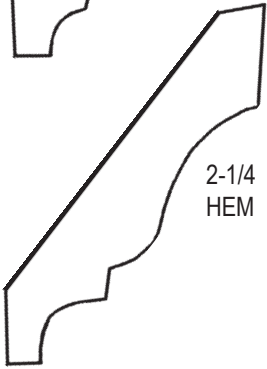
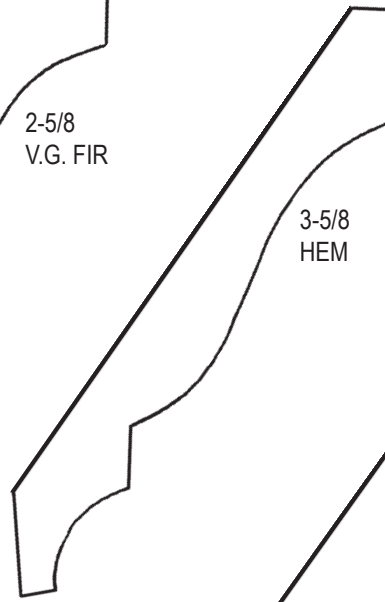
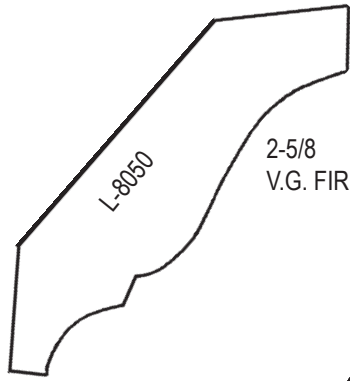

# RAKE MOULDING **FIR & HEM**

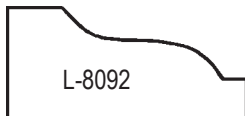

H-044  
9/16 X 1-1/4  
HEM

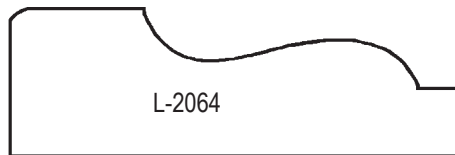

11/16 X 2-3/8  
V.G. FIR

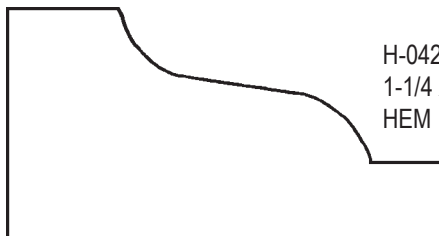

H-042  
1-1/4 X 2-1/4  
HEM

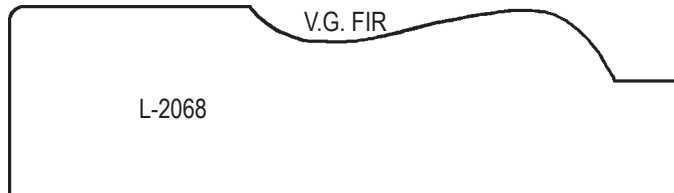

1" X 3-3/8  
V.G. FIR

## PICTURE, BATTEN, CHAIR RAIL **FIR&HEM**

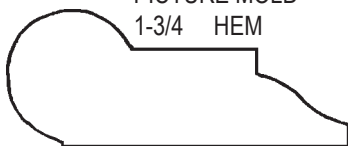

PICTURE MOLD  
1-3/4 HEM

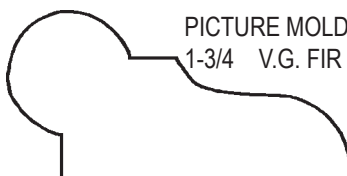

PICTURE MOLD  
1-3/4 V.G. FIR

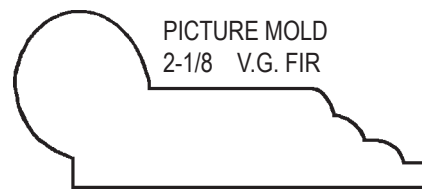

PICTURE MOLD  
2-1/8 V.G. FIR

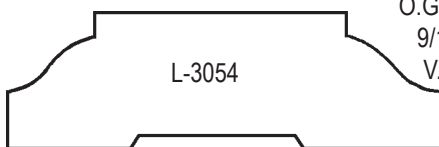

O.G. BATTEN  
9/16 X 2-1/4  
V.G. FIR



REEDED BATTEN  
5/8 X 2-3/8  
V.G. FIR



PANEL MOLD  
9/16 X 1-5/8  
HEM



PANEL MOLD  
9/16 X 1-9/16  
HEM

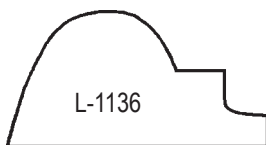

CHAIR RAIL  
5/8 X 1-5/16  
V.G. FIR



LOUIS CHAIR RAIL  
9/16 X 2-1/2  
HEM

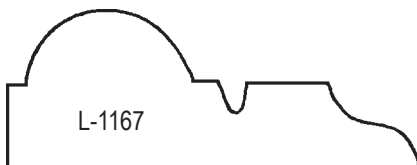

CHAIR RAIL  
13/16 X 2-1/16  
V.G. FIR

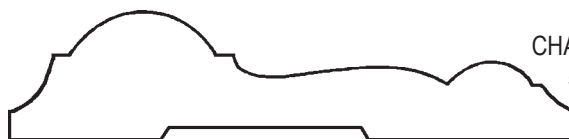

CHAIR RAIL  
5/8 X 3"  
HEM



CHAIR RAIL  
1" X 2-1/2  
V.G. FIR

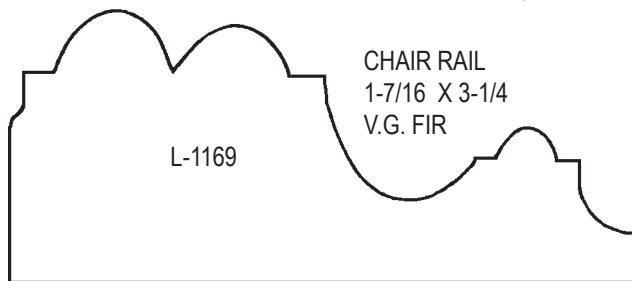

CHAIR RAIL  
1-7/16 X 3-1/4  
V.G. FIR

# BRICK & CORNICE MOLD FIR & HEM

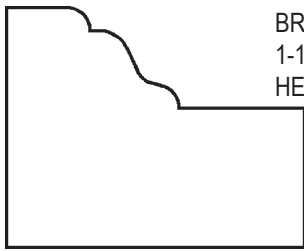

BRICK MOLD  
1-1/4 X 1-9/16  
HEM



BRICK MOLD  
1-3/8 X 2  
FIR

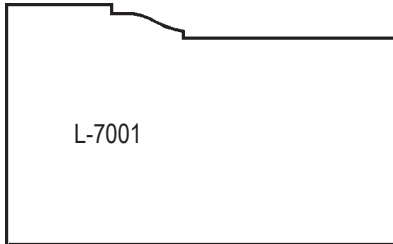

L-7001

BRICK MOLD  
1-1/4 X 2  
SOLID HEM &  
F/J PRIMED

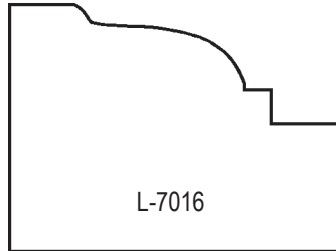

L-7016

CORNICE MOLD  
1-1/4 X 1-3/4  
V.G. FIR

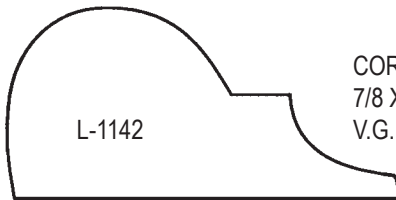

L-1142

CORNICE MOLD  
7/8 X 2"  
V.G. FIR

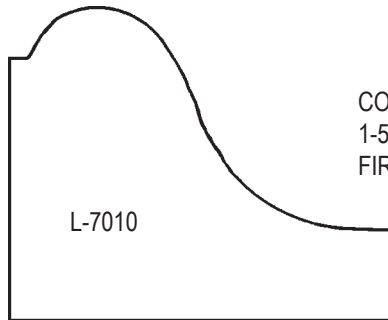

L-7010

CORNICE MOLD  
1-5/8 X 2'  
FIR

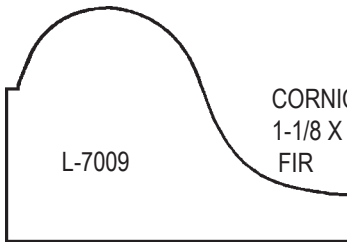

L-7009

CORNICE MOLD  
1-1/8 X 1-3/4  
FIR

# CAP & BACKBAND MOLD FIR

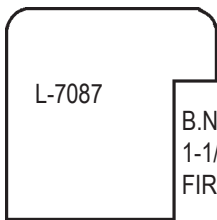

L-7087

B.N. BACKBAND  
1-1/8 X 1-1/8  
FIR

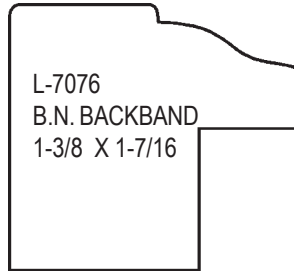

L-7076  
B.N. BACKBAND  
1-3/8 X 1-7/16

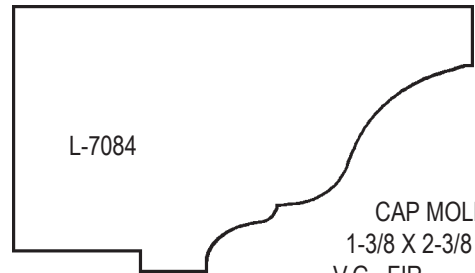

L-7084

CAP MOLD "A"  
1-3/8 X 2-3/8  
V.G. FIR

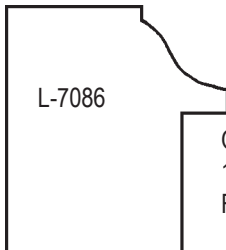

L-7086

O.G. BACKBAND  
1-1/8 X 1-5/16  
FIR

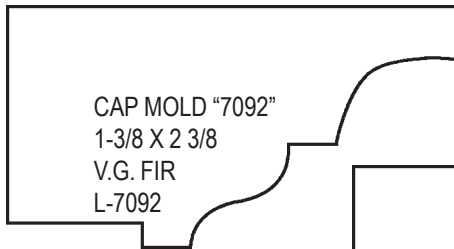

CAP MOLD "7092"  
1-3/8 X 2 3/8  
V.G. FIR  
L-7092



CAP MOLD "283"  
1-3/8 X 2-3/8  
V.G. FIR

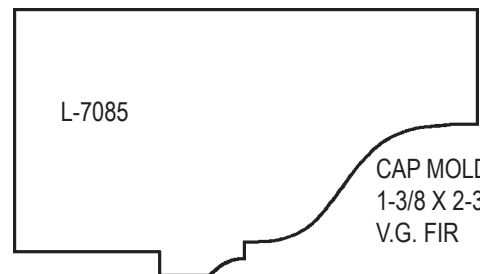

L-7085

CAP MOLD "B"  
1-3/8 X 2-3/8  
V.G. FIR

# RAILINGS **FIR & HEM**

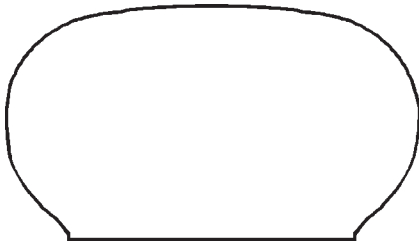

RAILING  
1-1/4 X 2-1/4  
(BREADLOAF)  
HEM

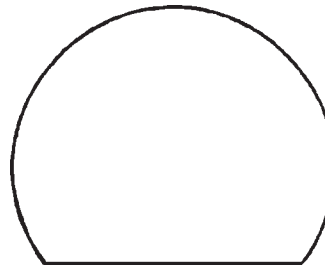

RAILING  
1-5/8 X 1-5/8  
(FLAT BOTTOM ROUND)  
HEM

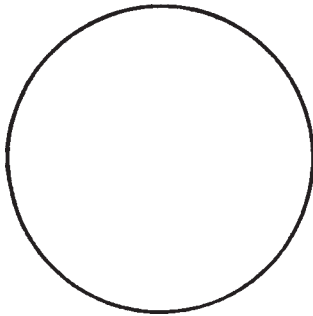

RAILING  
1-9/16 ROUND  
HEM

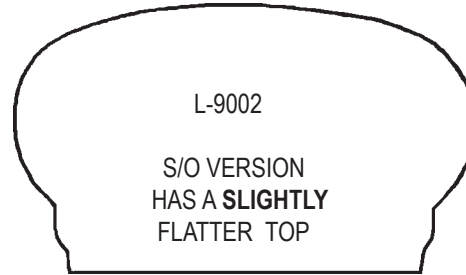

L-9002  
S/O VERSION  
HAS A **SLIGHTLY**  
FLATTER TOP

RAILING  
1-7/16 X 2-3/8  
V.G. FIR

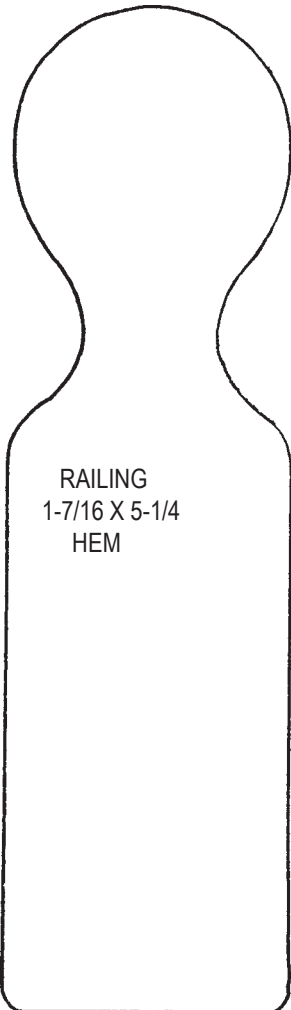

RAILING  
1-7/16 X 5-1/4  
HEM



RAILING  
1-7/16 X 5-1/4  
**CEDAR**  
**FINGER-JOINTED**

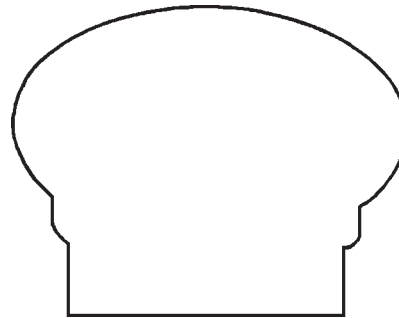

RAILING  
1-5/8 X 2"  
BREADLOAF  
V.G. FIR

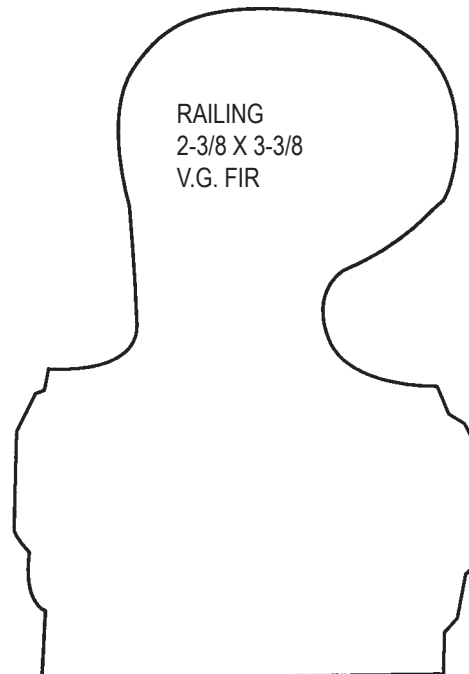

RAILING  
2-3/8 X 3-3/8  
V.G. FIR

# STOOL & NOSING **FIR**

---

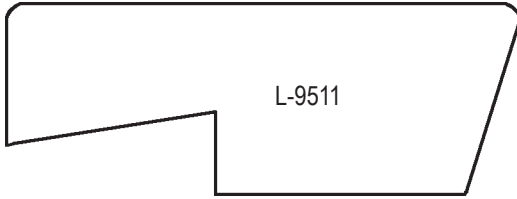

L-9511

WINDOW STOOL  
1" X 2-5/8  
V.G. FIR

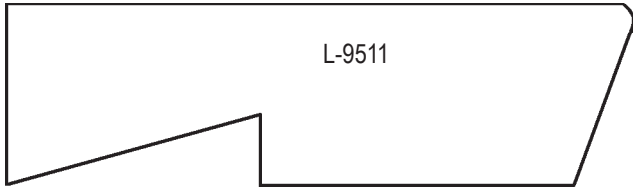

L-9511

WINDOW STOOL  
1" X 3-1/4  
V.G. FIR

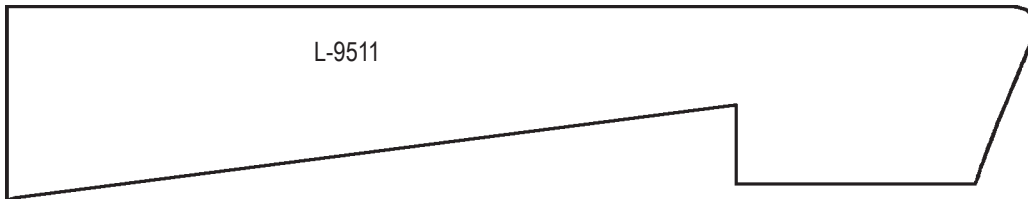

L-9511

WINDOW STOOL  
1" X 5-3/8  
V.G. FIR



L-9512

FRENCH STOOL  
1" X 5-3/8  
V.G. FIR

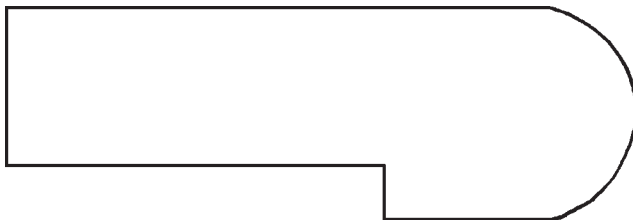

STAIR NOSING  
1" X 3-1/4  
V.G. FIR

# EXTERIOR APPLICATIONS

**CEDAR OR FIR**

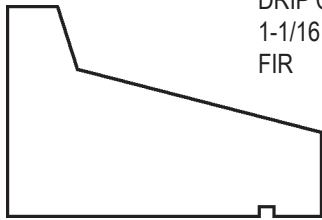

DRIP CAP  
1-1/16 X 1-5/8  
FIR

WATER TABLE  
2-3/8 X 3-1/4  
CEDAR

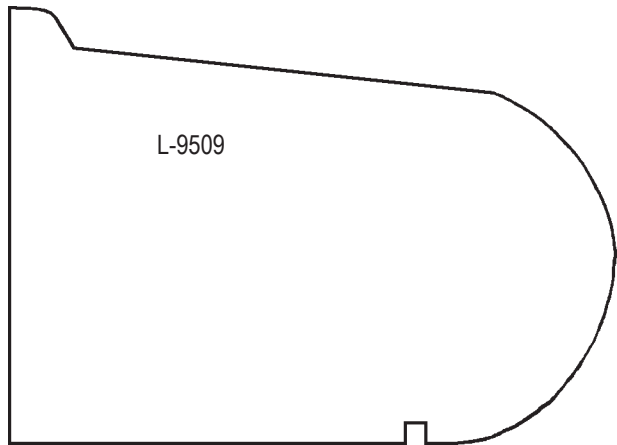

L-9509

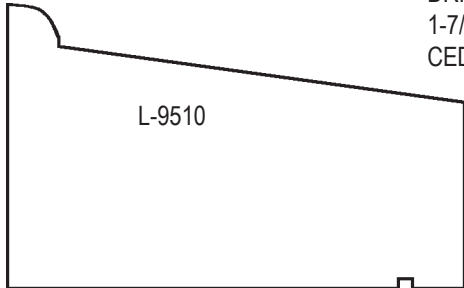

DRIP CAP  
1-7/16 X 2-3/8  
CEDAR

L-9510

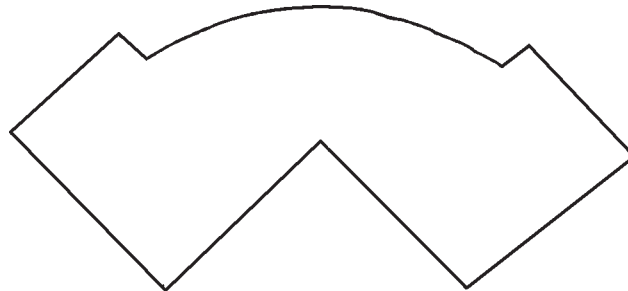

CORNERPOST  
2 X 4 FIR  
AVAILABLE SPECIAL ORDER  
@ 45 DEGREE  
(BAY WINDOWS)

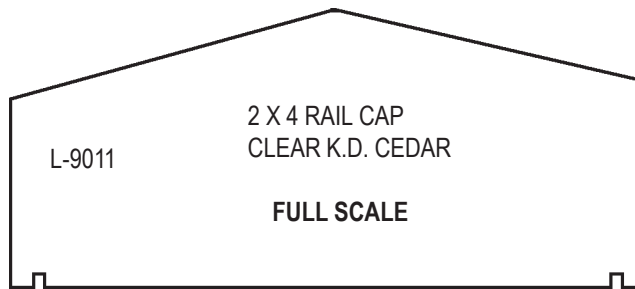

L-9011

2 X 4 RAIL CAP  
CLEAR K.D. CEDAR

**FULL SCALE**

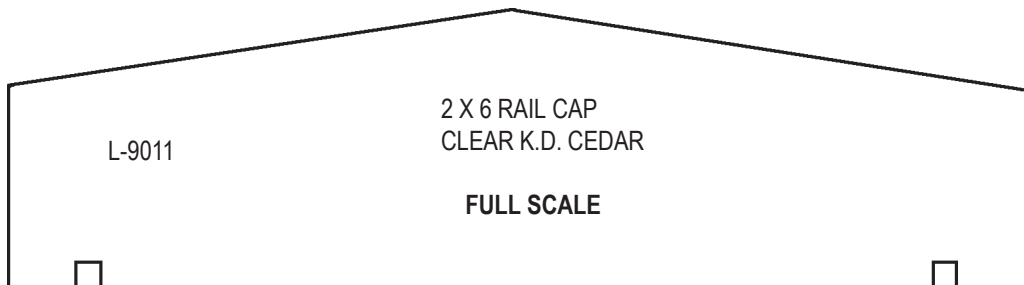

L-9011

2 X 6 RAIL CAP  
CLEAR K.D. CEDAR

**FULL SCALE**

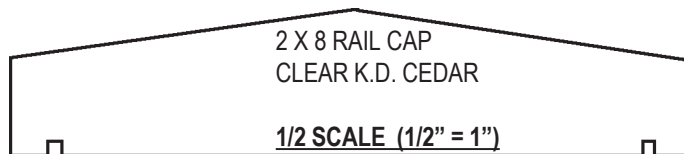

2 X 8 RAIL CAP  
CLEAR K.D. CEDAR

**1/2 SCALE (1/2" = 1")**

# MDF MOULDINGS

PRE-PRIMED UNLESS NOTED



BULLNOSE CASING  
5/8 X 2-1/4

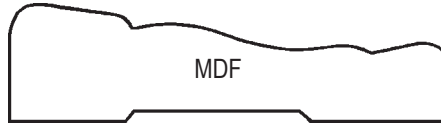

COLONIAL CASING  
9/16 X 2-1/4

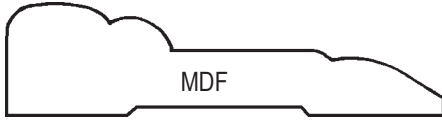

MOLDED CASING  
9/16 X 2-1/4

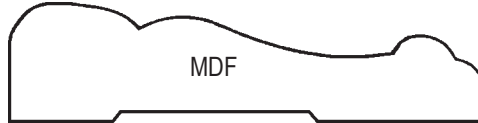

BEADED CASING  
5/8 X 2-1/2

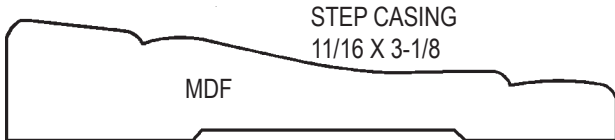

STEP CASING  
11/16 X 3-1/8



BEADED / FLUTED REVERSIBLE CASING---- 11/16 X 3-1/4



O.G. BASE  
1/2 X 2-1/4



O.G. BASE  
1/2 X 3-1/4



O.G. BASE  
1/2 X 5-1/4



COLONIAL BASE  
9/16 X 5-1/4

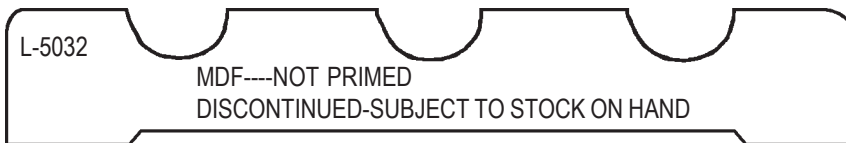

L-5032

MDF----NOT PRIMED  
DISCONTINUED-SUBJECT TO STOCK ON HAND

FLUTED CASING  
11/16 X 4-3/8



BED MOLD  
5/8 X 2-1/4

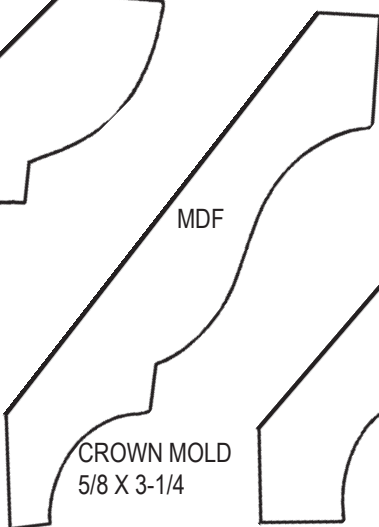

CROWN MOLD  
5/8 X 3-1/4

CROWN MOLD  
5/8 X 4-1/4

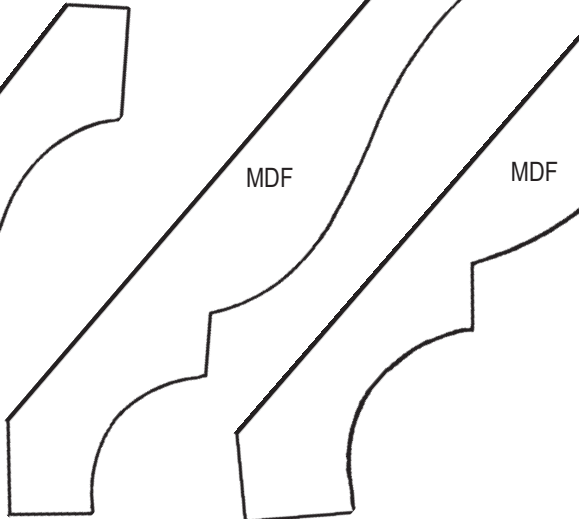

CROWN MOLD  
5/8 X 5-1/4

# RED OAK MOULDINGS (WHITE OAK BASESHOE)

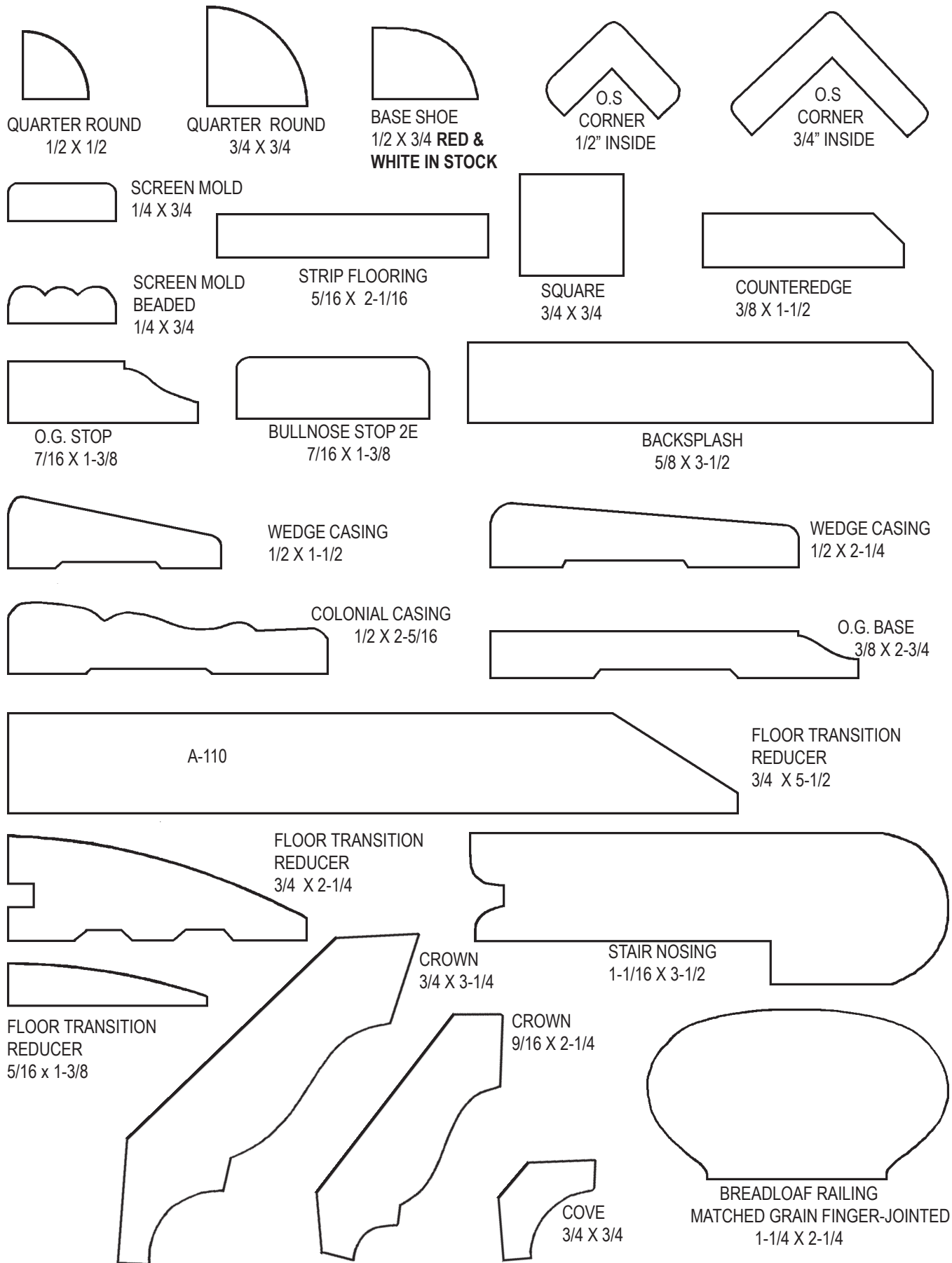

# MAHOGANY MOULDINGS

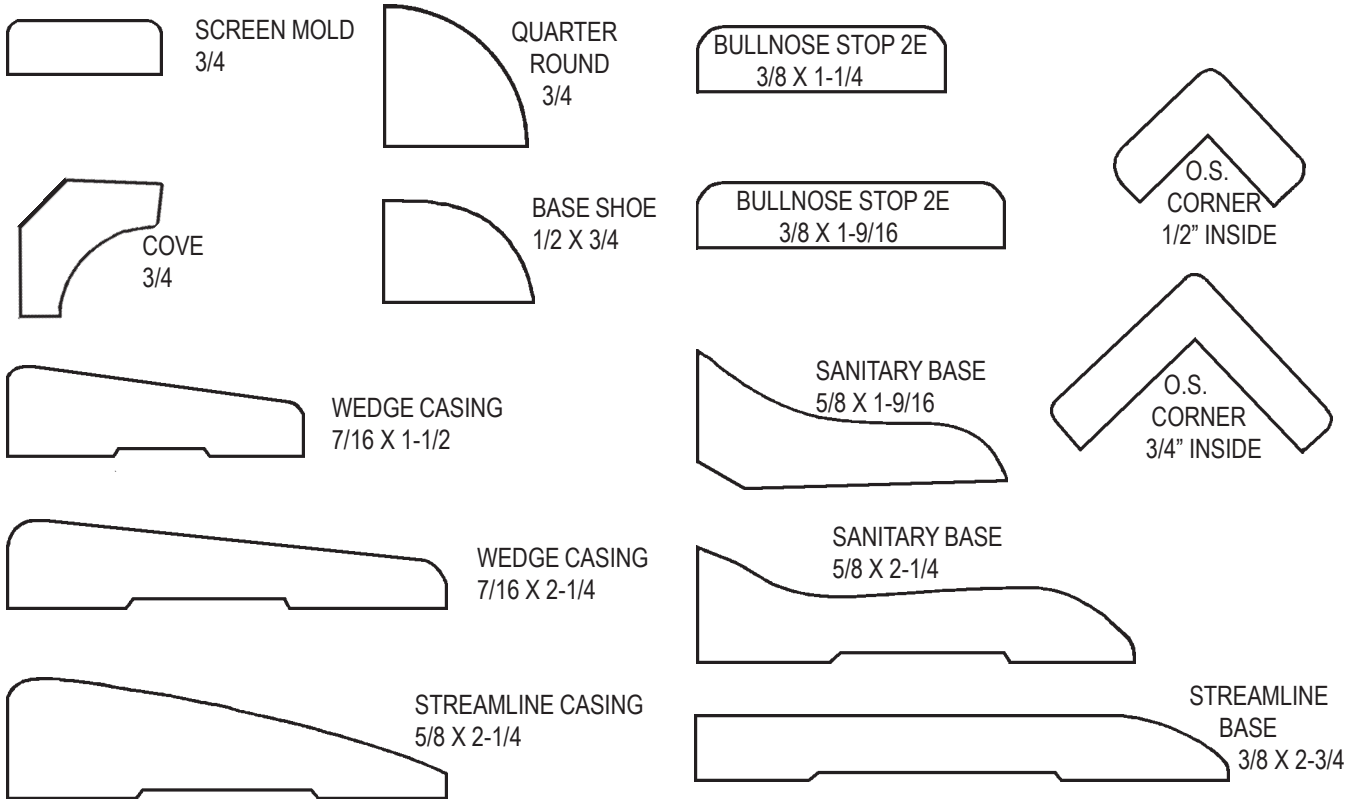

# MAPLE MOULDINGS

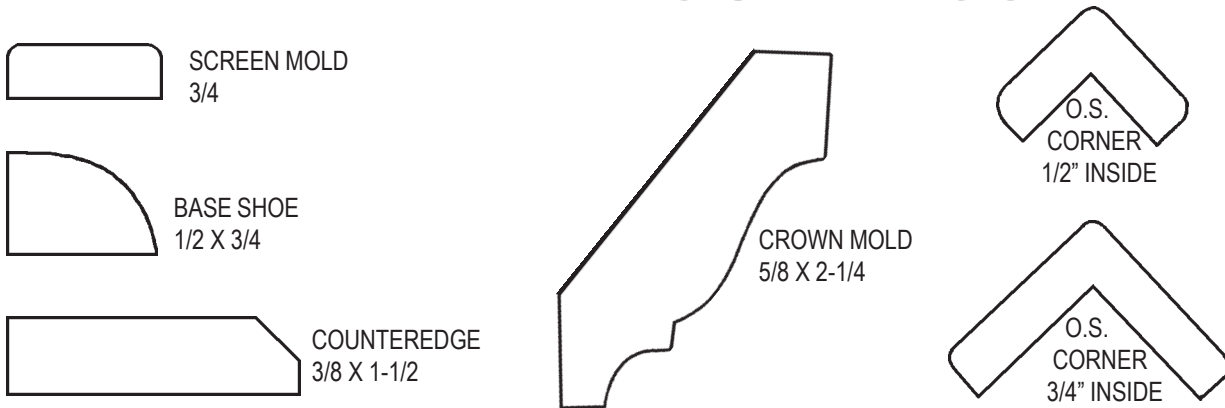

# TEAK MOULDINGS

